



BACKHUS 

Windrow Turner & Lane Turner

The realization that natural resources are finite has pushed people into thinking about their lifestyle. This is why we are now more attuned to the idea of nature being a valuable asset that needs to be safeguarded for future generations. The development of sustainable solutions is the active way to contribute to a future worth living, and is something that our employees engage in on a day-to-day basis.

Karlgünter Eggersmann,
CEO

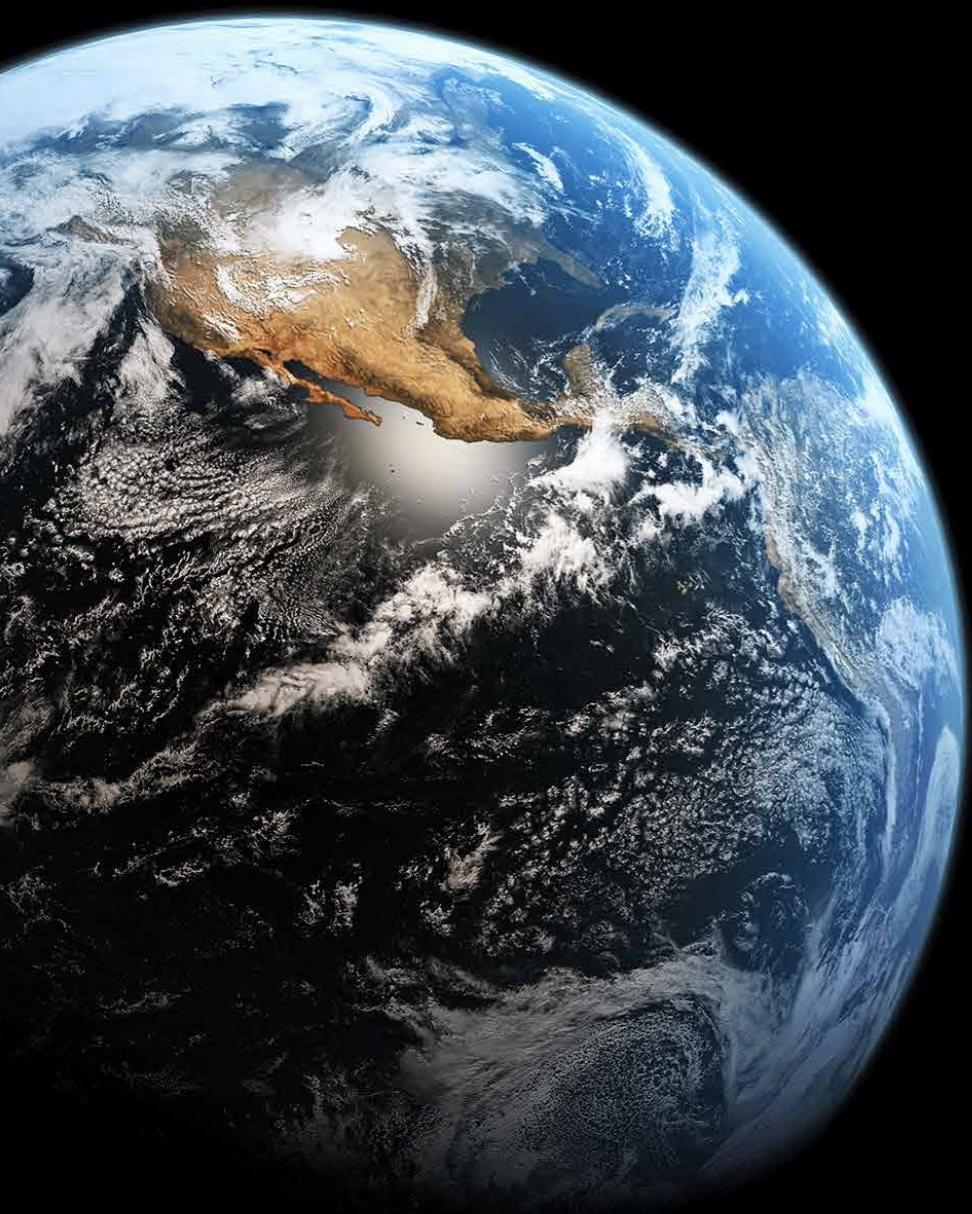

Navigation

- p. 4 BACKHUS A 30
- p. 6 BACKHUS A 36
- p. 8 BACKHUS A 45 - 65
- p. 10 BACKHUS A 75
- p. 12 BACKHUS Cabin equipment
- p. 14 BACKHUS Solutions
- p. 16 BACKHUS Windrow Turner comparison
- p. 18 BACKHUS Windrow Turner & CONVAERO System
- p. 20 The BACKHUS Lane Turner System
- p. 21 BACKHUS LT 30 - 50
- p. 22 BACKHUS LTC
- p. 24 Advantages of the BACKHUS Lane Turner System
- p. 26 BACKHUS LTC Mix Mixing System
- p. 30 References

BACKHUS A 30



Green waste from golf courses



BACKHUS A 30 in action

Easy Handling

The BACKHUS A 30 is a robust, compact and manoeuvrable turner that is easy to operate. It requires little maintenance and provides superior performance. The fully self-propelled BACKHUS A 30 is easy to transport and assures maximum flexibility. It is ideally suited for use in gardening, landscaping, fruit growing and market gardening sectors as well as for the maintenance of municipal parks and composting farmyard manure.

- Heavy-duty, compact design
- Economical diesel technology
- Height-adjustable, reversible rotor
- Fully hydraulic, low-maintenance drive
- Self-propelled, no tractor necessary - optimal utilization of space available
- Easy to transport and ready for use in no time at all
- Turning capacity up to 700 m³/h



Farmyard manure



Dimensions



mm

length 2,600,
width 3,550, height 1,900,
rotor diameter 730

Engine



YANMAR

Yanmar 4TNV88 34 kW
(45 PS) @ 2,400 rpm or
Yanmar 4TNV88 35.4 kW
(48 PS) @ 3,000 rpm

Turning capacity



up to 700 m³/h

Windrow



width: up to 3.0 m
height: up to 1.3 m



Green waste from parks



Adjustable track clearers



Intuitive operation by hand control



Easy maintenance



Self-propelled, no tractor necessary



Finished compost

BACKHUS A 36



Attractive Price-Performance Ratio

A proven concept with short payback. The BACKHUS A 36 is a great value and an ideal entry level machine into professional composting at a very reasonable price. This turner is already one of the most efficient solutions within its class.

- High performance diesel engine with low emissions
- Simple handling and optimum ergonomics
- Compact transport dimensions
- Easy to maintain construction
- Low ground pressure for gentle turning

Dimensions



mm

length 4,200,
width 4,200, height 3,350,
rotor diameter 950

Engine



VOLVO

Volvo TAD 5x0 105 kW
(143 PS) @ 1,800 rpm

Turning capacity



up to 1,500 m³/h

Windrow



width: up to 3.6 m
height: up to 1.8 m



Control via Joystick



Easy maintenance



High performance diesel engine with low emissions



Simple handling and optimum ergonomics



BACKHUS A 45 - 65

More Than Just an Option

Small fuel consumption and large turning capacities. The largest variety of options allow individual solutions for each customer. No matter what windrow width you choose, BACKHUS' low maintenance and great efficiency continue to set industry standards. Or to put it simple:

- High performance
- Low fuel consumption
- Customizable for any task
- Comfortable and easily accessible panoramic cabin
- Easy access for routine maintenance and service
- Long list of standard features
- Outstanding turning capacity up to 5,000 m³/h



Dimensions



mm

Engine



VOLVO

Turning capacity



Windrow



	Dimensions	Engine	Turning capacity	Windrow
BACKHUS A 45	length 4,900, width 5,200, height 4,500, rotor diameter 1,200	Volvo TAD 5x2 VE 160 kW (218 PS) @ 1,800 rpm	up to 2,800 m ³ /h	width: up to 4.5 m height: up to 2.3 m
BACKHUS A 50	length 5,100, width 5,700, height 4,650, rotor diameter 1,200	Volvo TAD 8x3 VE 235 kW (320 PS) @ 2,200 rpm	up to 3,600 m ³ /h	width: up to 5.0 m height: up to 2.4 m
BACKHUS A 55	length 5,100, width 6,200, height 4,750, rotor diameter 1,200	Volvo TAD 8x3 VE 235 kW (320 PS) @ 2,200 rpm	up to 4,000 m ³ /h	width: up to 5.5 m height: up to 2.5 m
BACKHUS A 60	length 6,000, width 6,700, height 5,050, rotor diameter 1,400	Volvo TAD 13x3 VE 345 kW (470 PS) @ 1,900 rpm	up to 4,600 m ³ /h	width: up to 6.0 m height: up to 2.7 m
BACKHUS A 65	length 6,000, width 7,200, height 5,200, rotor diameter 1,400	Volvo TAD 13x3 VE 345 kW (470 PS) @ 1,900 rpm	up to 5,000 m ³ /h	width: up to 6.5 m height: up to 2.9 m



Armoured rotor tools



User-friendly maintenance and service



Low fuel consumption



Control via operation panel

BACKHUS A 75



Outstanding Performance

Outstanding performance is a result of cutting edge technology. With an outstanding turning capacity of up to 6,800 m³/h, extreme sturdiness and intelligent technology the BACKHUS A 75 meets all demands of modern turning. No matter what working width you may choose, your BACKHUS will set new standards in power, efficiency and handling.

- World's largest serial turner
- Long list of standard features such as load adjusting automatic speed control (BTC)
- Easily accessible panoramic cabin which combines convenience and high performance
- Easy access for routine maintenance and service
- High quality and outstanding efficiency even in the heaviest working conditions
- Strong engine - Volvo TAD 16x1 VE 450 kW (612 PS) @ 1,800 rpm

Dimensions



mm

length 6,350,
width 8,200, height 5,600,
rotor diameter 1,800

Engine



VOLVO

Volvo TAD 16x1 VE 450 kW
(612 PS) @ 1,800 rpm

Turning capacity



up to 6,800 m³/h

Windrow



width: up to 7.5 m
height: up to 3.3 m

BACKHUS
A 75



Cabine with 360° panoramic view



Ground adjusting track clearers



Intelligent space utilization
Side Conveyor



Control via touch panel



BACKHUS A-series

Cabin equipment

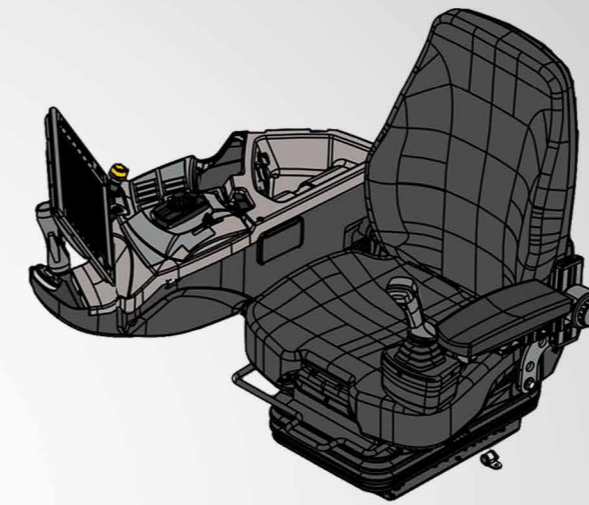

Size: 12.1" color screen (18 Bit)
Resolution: 1024x768
Backlight: LED
Controls: 13 keys,
1 cross switch with pressure function, Touchscreen

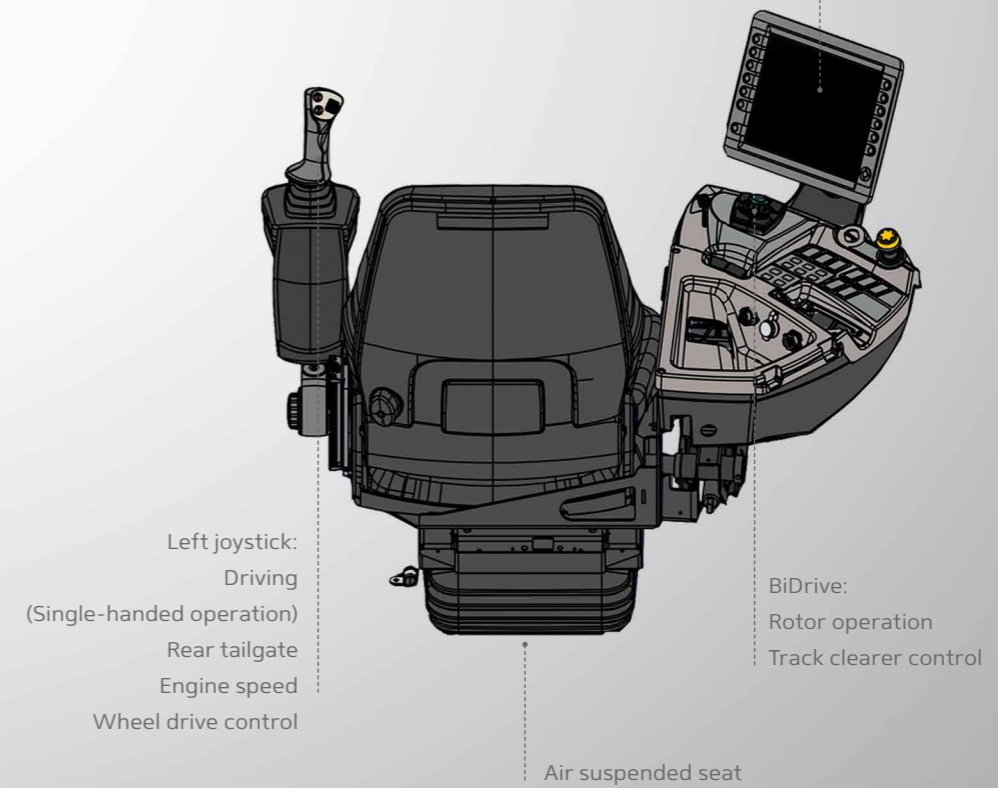

BACKHUS Solutions

Various concepts for specific waste management and composting require specific and distinctive solutions. We offer a unique set of continuously developed project solutions for your individual concepts. You will find your personal contacts at www.f-e.de.

- World's largest range of optional features
- Optimizing operating costs
- Solutions for emissions reduction
- Individual development for custom made projects
- Practical consulting and project solutions in dialogue with the customer

BTC Automation speed control -
BACKHUS Track Control (BTC)

BMS Maximum Power and Maximum Efficiency -
BACKHUS Management System (BMS)



Concentrate injection for process optimization -
for fast composting



Process optimization -
injecting water during turning



BACKHUS HD ME,
Radio controlled - hose drum with 2" or 3" connection



BACKHUS HD S,
Radio controlled - hose drum with 3" or 4" connection



Professional optimization of
the composting process -
BACKHUS Fleece Winder



For increased traction on
loose ground -
the landfill undercarriage



In motion -
the mobile cab



Intelligent space utilization -
Side Conveyor



Reduce dust and odour -
enclose it



CONVAERO Bio-Dry System -
membrane covered

BACKHUS A-series

Windrow Turner Comparison

Dimensions

Engine

Turning capacity

Windrow



mm

YANMAR

BACKHUS **A 30**



length 2,600, width 3,550, height 1,900, rotor diameter 730

Yanmar 4TNV88 34 kW (45 PS) @ 2,400 rpm or Yanmar 4TNV88 35.4 kW (48 PS) @ 3,000 rpm

up to 700 m³/h

width: up to 3.0 m
height: up to 1.3 m

BACKHUS **A 36**



length 4,200, width 4,200, height 3,350, rotor diameter 950

VOLVO

Volvo TAD 5x0 105 kW (143 PS) @ 1,800 U/min

up to 1,500 m³/h

width: up to 3.6 m
height: up to 1.8 m

BACKHUS **A 45**



length 4,900, width 5,200, height 4,500, rotor diameter 1,200

VOLVO

Volvo TAD 5x2 VE 160 kW (218 PS) @ 2,300 rpm

up to 2,800 m³/h

width: up to 4.3 m
height: up to 2.1 m

BACKHUS **A 50**

length 5,100, width 5,700, height 4,650, rotor diameter 1,200

Volvo TAD 8x3 VE 235 kW (320 PS) @ 2,200 rpm

up to 3,600 m³/h

width: up to 5.0 m
height: up to 2.4 m

BACKHUS **A 55**

length 5,100, width 6,200, height 4,750, rotor diameter 1,200

Volvo TAD 8x3 VE 235 kW (320 PS) @ 2,200 rpm

up to 4,000 m³/h

width: up to 5.5 m
height: up to 2.5 m

BACKHUS **A 60**

length 6,000, width 6,700, height 5,050, rotor diameter 1,400

Volvo TAD 13x3 VE 345 kW (470 PS) @ 1,900 rpm

up to 4,600 m³/h

width: up to 6.0 m
height: up to 2.6 m

BACKHUS **A 65**

length 6,000, width 7,200, height 5,200, rotor diameter 1,400

Volvo TAD 13x3 VE 345 kW (470 PS) @ 1,900 rpm

up to 5,000 m³/h

width: up to 6.5 m
height: up to 3.0 m

BACKHUS **A 75**



length 6,350, width 8,200, height 5,600, rotor diameter 1,800

VOLVO

Volvo TAD 16x1 VE 450 kW (612 PS) @ 1,800 rpm

up to 6,800 m³/h

width: up to 7.5 m
height: up to 3.3 m

WINDOW GEOMETRY



Windrow Geometry		A 30	A 36	A 45	A 50	A 55	A 60	A 65	A 75
Windrow width (B _{Auf})	m	3.0	3.6	4.3	5.0	5.5	6.0	6.5	7.5
Windrow height (H _M)	m	1.3	1.8	2.3	2.4	2.5	2.7	2.9	3.3
Windrow cross section	m ²	2.2	3.2	5.1	6.2	7.5	8.9	10.4	13.9



The best synergy: a combination of windrow turner with integrated cover winder and the membrane covered system.

Turning the covered compost windrow by a windrow turner with integrated cover winder is an almost enclosed operation. Rolling up the membrane, turning of the material, spraying of water (optional) and covering the material with the membrane again can be done simultaneously in one working step. This optimizes the process time, reduces space requirement and labour cost. High moisture content materials can be composted even when bulking agent is scarce.

BACKHUS Model BACKHUS A 50 to A 75 work seamlessly with CONVAERO System for windrow width ranging from 5.0 m to 7.5 m and windrow length up to 100 m.

For higher throughput or high moisture content input material, BACKHUS CON 60, CON 75 and CON 100 are specially constructed to drive over side walls up to 1.20 m high. These models are suitable for windrow width of 6.0 m, 7.5 m and 10.0 m with a correspondingly higher volume.



CONVAERO System

The Bio-Dry process takes benefit from the natural biodegradation of organic matters by microorganism existing in waste. Special designed membrane cover is placed over waste heap, air channels in the floor provide sufficient flow of air through the waste. In this controlled and monitored environment, the microorganism decompose organic matter and heat is produced as part of the metabolic activities, which causes the temperature in the waste heap and under the cover to rise. Depending on client's requirements, the process is customized according to the purpose of waste drying or composting.

For waste drying, temperature rises to 60 - 70 degree Celsius to evaporate water in the waste. After 2 to 4 weeks, what remains of the waste is a dry, odourless and stabilized substance which is easy to handle and separate.

While for composting, temperature of 60 - 70 degree Celsius sanitizes the waste. The process is designed to provide sufficient O₂ to maintain aerobic condition and this creates an ideal environment for degradation of waste.

System Features

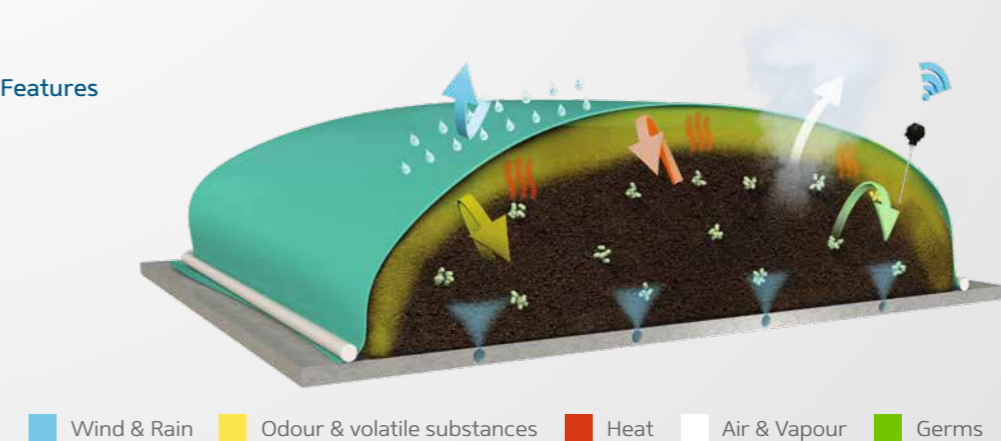

The BACKHUS Lane Turner System

Maximum efficiency in the fields of:

Composting

(organic fraction from household waste, biological waste)

- Max. decomposition of biologically and aerobically degradable dry organic substances
- This process results in a biologically stable end product
- Compost rich in humus in the case of composting of biological waste
- Deposit with low breathability in the case of composting of an organic fraction of household waste
- The reduced biological activity is due to the decomposition of the dry organic substance during the composting process

Biological drying (organic fraction or household waste)

- Max. discharge of water from the input material using the heat released during the aerobic biodegradation of the dry organic substance
- This process results in a dry and stabilized end product
- Subsequent mechanical treatments (screening, sifting, etc.) are possible
- The reduced water content increases the calorific value of the material
- The stabilization and the reduced biological activity is due to the significantly lower water content of the material during the drying process

Composting of sewage sludge

- Fast drying and hygienization of the sewage sludge
- Generation of a product with a reduced volume that is suitable for storage
- The compost from sewage sludge is a stabilized organic fertiliser with a medium nutrient content
- Dried sewage sludge is a free-flowing substitute fuel with a low to medium calorific value

Soil decontamination

- Continuous homogenizing of the soil by frequent turning
- Breaking of lumps and soil agglomerates to create new surfaces
- Optimized aeration by decompaction of the material
- More efficient distribution of the moisture and prevention of waterlogging
- Improved application and distribution of liquid or granulated substances
- Faster decontamination process due to the maintenance of the best possible conditions
- Improved controllability and handling of the decontamination process





BACKHUS LT 30 - 50



Forward Thinking Waste Management –

for enclosed applications and indoor plants. The BACKHUS Lane Turner incorporates the proven plant technology of BACKHUS. It offers high efficiency and turning performance and combines great economy, low maintenance and long life for composting, bioremediation and MSW treatment between lane walls or in tunnels.

- Intelligent waste management for indoor plants
- Tailor made integration into new or existing plants
- Half or fully automatic operation of turner and material flow
- Optional electronic or diesel engine
- Highly efficient material flow and batch process

	Dimensions	Engine	Turning capacity	Lane, Material approx.
	 mm			
BACKHUS LT 30	rotor diameter 1,400	Electric Engine app. 1x11 kW (15 PS) + 1x110 kW (150 PS)	up to 800 m ³ /h	width: up to 3.0 m height: up to 2.0 m
BACKHUS LT 45 - 50	rotor diameter 1,800	Volvo TAD 8x3 VE 235 kW (320 PS) or Volvo TAD 1371 VE 285 kW (388 PS)	up to 2,000 m ³ /h	width: up to 4.5 - 5.0 m height: up to 2.2 - 2.7 m



Armoured rotor tools



Half or fully automatic operation of turner and material flow



Easy access for routine maintenance and service



Tailor made integration into new or existing plants

The System for Closed Lane Composting:

- Closed dynamic system
- Fully automated material feed and output
- Fully automated material transport within the lanes by regular turning
- Optimized oxygen supply through pressure ventilation
- Optimized water output through pressure ventilation
- Fully automated process control
- Exhaust treatment of process and hangar exhaust

Advantages of the Dynamic Treatment Procedure Compared to Static Procedures:

- Homogenization and aeration of the material by turning in one step
- Prevention of anaerobic areas
- Efficient moisture management during turning ensures optimum water balance
- Optimized process control and shorter treatment times

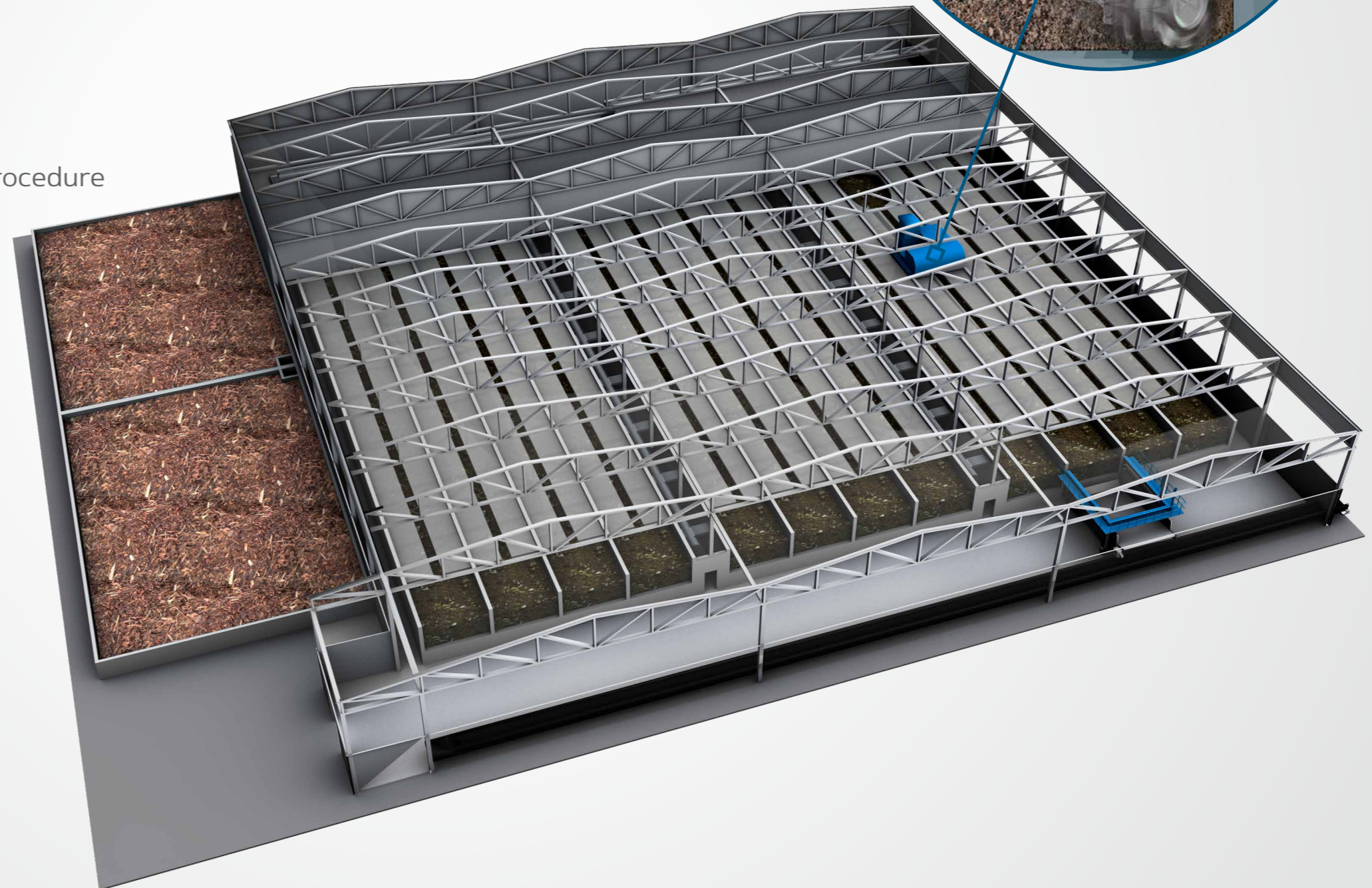



Different operating procedures	Batch operation	Flow through operation
Optimum process control	✓	
Optimum turning intervals	✓	
Automatic flow of material		✓
Input by conveyor equipment		✓
Input by wheel loader	✓	✓
Output by conveyor equipment		✓
Output by wheel loader	✓	✓



Cabin

Computer

Advantages of the BACKHUS Lane Turner System Compared to Other Lane Turners:

- High turning capacity up to 1,500 m³/h shorten the operation time inside the composting hall
- Different lane widths and heights possible
- Batch or flow through operation possible. Optimized oxygen supply through pressure ventilation
- Turners can either be driver operated or computer controlled
- Transfer between lanes by transfer vehicle or concrete platform
- Flexible plant design, less capital expenditure and lower operating costs



Transfer waggon / platform



Input by wheel loader



Conveyor equipment



Output by wheel loader



Conveyor equipment

BACKHUS LTC Mix

Mixing System



Mixing with

BACKHUS LTC Mix

low in emissions, fast and efficient

All benefits at a glance:

- fully automated process
- application within closed systems
- optimum material mix in the end

The mixing process

Instead of increasing it, BACKHUS LTC Mix decreases the material's compactness. Its mixing results are optimal thanks to turning the material twice in succession. While it pre-mixes the material and breaks up possible clumps in the first cycle, the second turning significantly contributes to improving the result.

Fully automated process

The entire process, including the controls of the BACKHUS LTC Mix, is regulated by a computer-operated system.

Low-emission process

BACKHUS LTC Mix – Lane Turner Closed Mix – serves as an alternative to mixing in the open within closed systems. The emissions produced during the mixing process by the encapsulated system are collected and guided to the flue gas treatment system. Emissions – especially odour emissions – are thus reduced significantly.

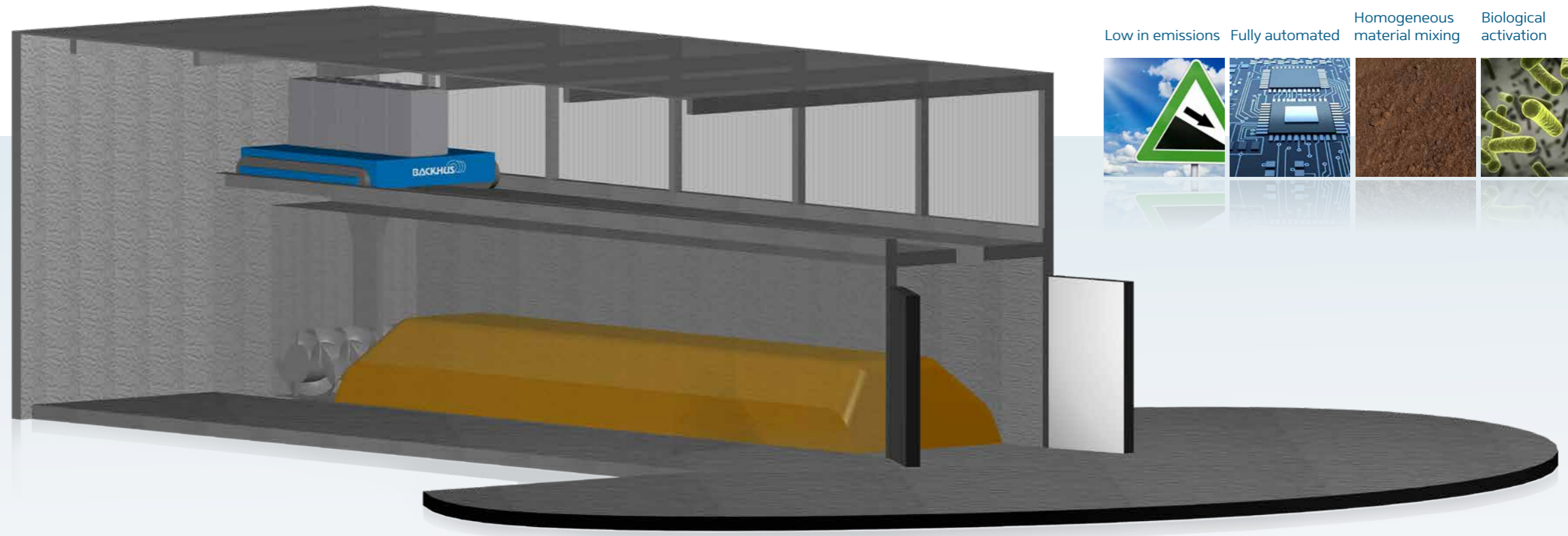
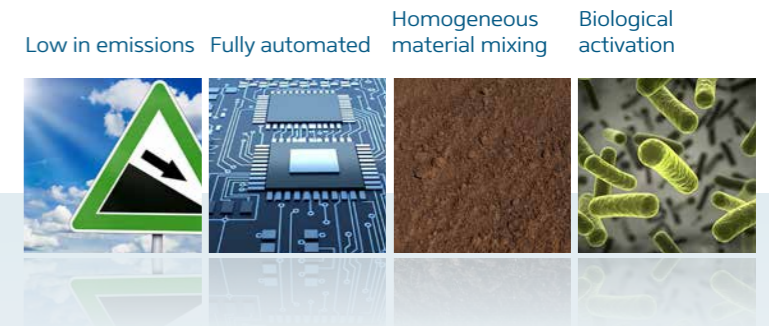

Application

The base material consists of one part fermentation residues and one part structural material. BACKHUS LTC Mix creates a well-rotting substrate which means a well-ventable, almost homogeneous material with corresponding air pore volume.

Dimensions

Rotor diameter	14 m
Total rotor width	4.0 m
Length	5.5 m
Width	3.9 m
Height	4.0 m
Material height	1.8 m
Ground clearance max.	20 ± 50 mm

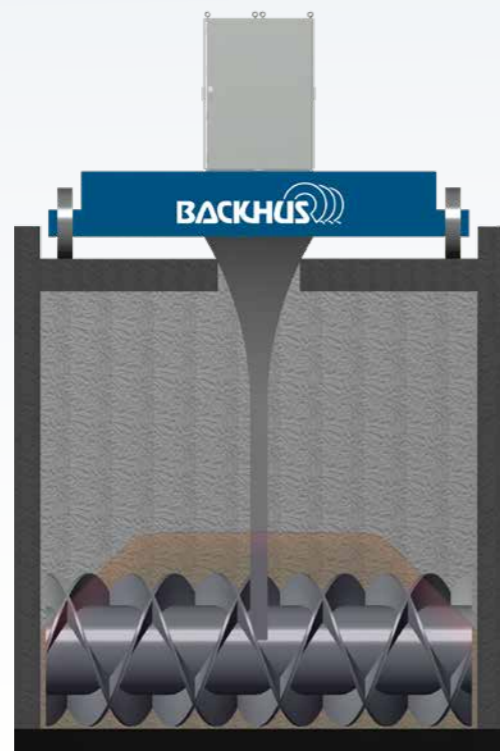

References



Biological Drying

Project start: 06/2011
 Location: Poland, Gdańsk
 Material: MSW
 Input capacity: 40,000 t/a
 Usage: RDF / deposit
 Process design: cyclic process with 21 days of composting followed by a maturity phase
 System design: 14 lanes, closed building
 Lane length: 50 m
 Lane width: 5 m
 Filling height: 2.7 m, input and output via conveyor systems
 Ventilation: ventilation by suction
 Irrigation: integrated in BACKHUS LT daily
 Turning frequency: daily
 Machine: BACKHUS LT 50.27 D AR, BACKHUS TW 50.27 AR, Process Control System



Sewage Sludge Composting

Project start: 09/2009
 Location: China, Zhengzhou
 Material: sewage sludge with peanut shells
 Input capacity: 130,000 t/a
 Usage: compost for agricultural use
 Process design: batch process with 28 days of composting
 System design: 66 lanes, closed building
 Lane length: 33 m
 Lane width: 4.5 m
 Filling height: 2 m, input and output via wheel loader, output partly via conveyor systems
 Ventilation: subfloor ventilation, pressure ventilation
 Irrigation: none
 Turning frequency: every second day
 Machine: 2 x BACKHUS LT 45.20 DC



Composting

Project start: 03/2012
 Location: Germany, Ratingen
 Material: organic waste (SSO)
 Input capacity: 50,000 t/a
 Usage: compost for agricultural use, horticulture, landscaping and end users
 Process design: cyclic process with 28 days of composting followed by a maturity phase
 System design: 12 lanes, closed building
 Lane length: 48 m
 Lane width: 5 m
 Filling height: 2.7 m, input and output via conveyor systems
 Ventilation: ventilation by suction
 Irrigation: integrated in BACKHUS LT
 Turning frequency: three times per week
 Machine: BACKHUS LT 50.27 D AR, BACKHUS TW 50.27 AR, output system, Process Control System



Composting of Digestate

Project start: 2013
 Location: Spain
 Material: composting of digestate and structure material
 Input capacity: 38,000 t/a
 Usage: compost for agricultural use
 Process design: flow through process with 14 days of composting
 System design: 10 lanes, closed building
 Lane length: 37 m
 Lane width: 3 m
 Filling height: 2 m, input via conveyor belt
 Ventilation: subfloor system, ventilation by suction
 Irrigation: by BACKHUS LT
 Turning frequency: daily
 Machine: BACKHUS LT 30.20 EA, BACKHUS TW 30.20, Process Control System



Eggersmann

Recycling Solutions



Eggersmann GmbH

HQ | Halle
Ravenna-Park 2
33790 Halle (Westf.)
Germany

sales@f-e.de
www.f-e.de

Technology Center | Turning
Rothenschlatt 18
26203 Wardenburg
Germany

Fon +49 4407 9133-700
Fax +49 4407 9133-701

Eggersmann Anlagenbau GmbH

Carl-Zeiss-Straße 6-8
32549 Bad Oeynhausen
Germany

Fon +49 5734 6690-100
Fax +49 5734 6690-140

anlagenbau@f-e.de



Find us on

