

UNTHA

The reliable brand!



LR630

Shredding solution for economic
processing of waste wood

The tried-and-tested UNTHA cutting system

Single-shaft cutting system:

The single-shaft cutting system was developed for efficient shredding, a long service life of the indexable inserts and low maintenance. Together with the high-performance power train, it ensures the reliable shredding of residual wood, both with and without a pusher system.

Smooth rotor shape

The smooth, full-steel rotor enables the indexable inserts to dig deeper into the material than a highly profiled rotor, resulting in excellent material feed-in.

Cut-as-you-pull

The unique shape of the indexable inserts makes for a “cut-as-you-pull” effect, which means that the unit requires less power and achieves a higher throughput.

Screwed-in blade holders

The screwed-in, exchangeable blade holders are easy and quick to replace in case of damage (for instance caused by solid metal parts).

Reusable indexable inserts

Each side has a long lifespan, making the cutting system particularly low maintenance. The flat shape of the blade ensures a higher throughput, reduces wear and tear and is not susceptible to non-shreddables made of metal.

Low-wear main cutting bar

The low-wear main cutting bar lowers maintenance costs.

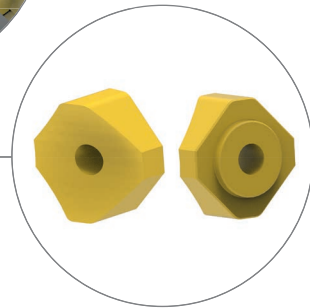
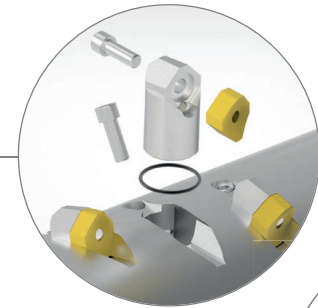
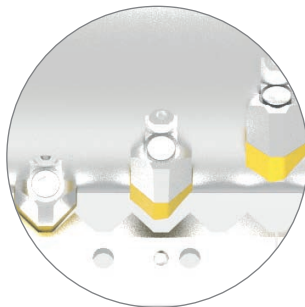

LR630

Single-shaft shredding system

The LR630 is an absolute classic among single-shaft shredders, offering a robust design and excellent value for money. It is mostly used by carpentry and joinery workshops that have small to medium-sized volumes of residual wood.

The high-performance drive concept, a powerful horizontal pusher and the tried-and-tested UNTHA cutting system make for a highly reliable shredding process. The homogeneous final product is extremely well suited for use in a wood-chip heating system or for manufacturing wood briquettes.

A low rated capacity and automatic shut-off in case of idling considerably reduce energy costs.

Areas of application

- » Hard and soft wood
- » OSB
- » Chipboard panels
- » MDF panels
- » Veneers
- » etc.



Your benefits at a glance

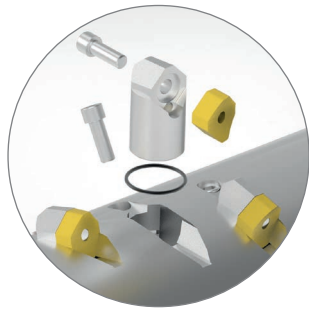

Reliable, cost-effective cutting system

The large rotor diameter (248 mm) and screen surface ensure a high throughput.

The screw-in, exchangeable blade holders are easy and quick to replace in case of damage (for instance caused by solid metal parts). The precise cutting gap between the cutting bar and the indexable inserts makes the shredding process particularly efficient.

Unique geometry of the indexable inserts

The reusable indexable inserts have a long service life. Their unique cutting geometry ensures a “cut-as-you-pull” effect that makes for particularly effective shredding even of wet wood.

The positive connection between the indexable insert and the blade holders prevents the fastening bolt from becoming deformed. It is easy to loosen and remove even after many hours of operation.



Low-wear perforated screen

Depending on the requirements, a range of screens ensure the production of pre-defined wood chips. The shredded material is then removed via a suction mechanism or a screw conveyor.

The special design of the perforated screen provides a particularly homogeneous final product without excess lengths that is ideal for briquetting or use in a wood-chip heating system.

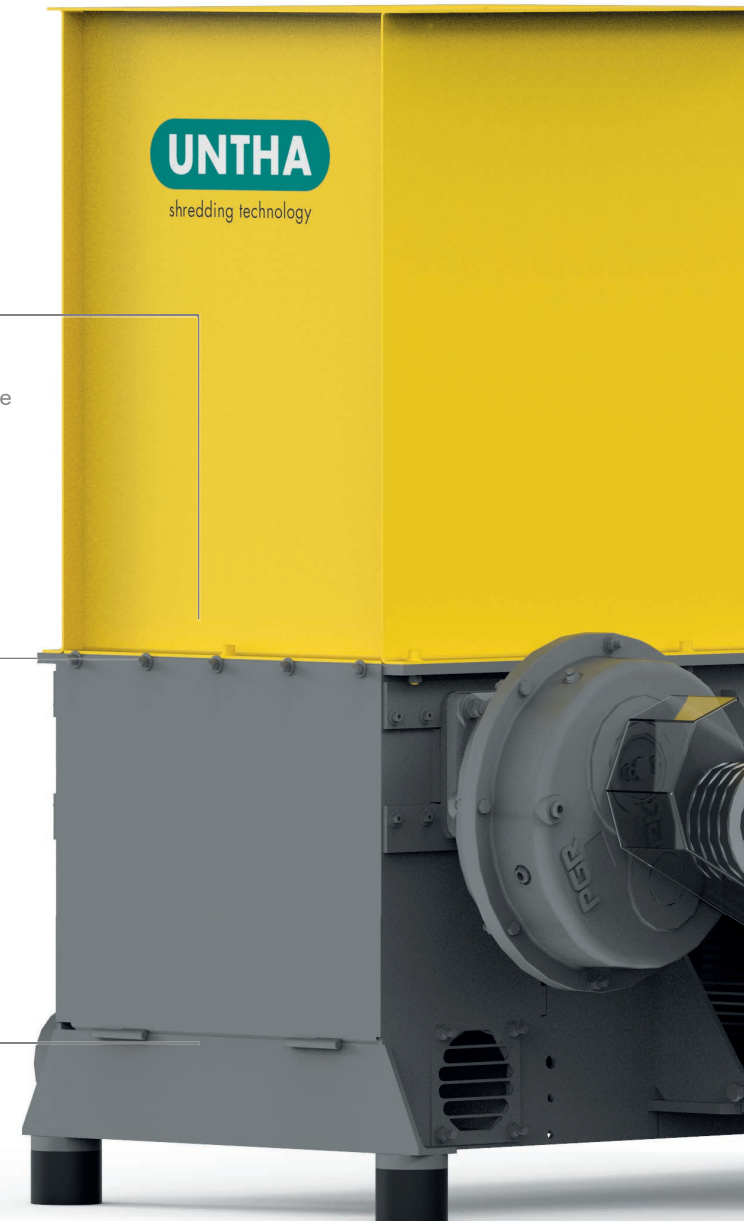

Unique warranty

As a proof of our excellent product quality, we are happy to offer you a 3-year warranty*. Many renowned companies already put their trust in our quality standards.

*3 years or 2000 hours, depending on which value is reached first.



Powerful pusher system

The powerful horizontal pusher pushes the residual wood against the rotor (load-dependent), ensuring a constant material feed. The hydraulic power unit is safely integrated in the machine frame and yet easily accessible.

Energy-efficient, failure-free drive concept

The tried-and-tested belt drive and elastomer damper absorb shocks and vibrations and ensure the smooth running of the machine. The automatic reverse function, detection of non-shreddables and shut-off function protect the drive unit. The automatic shut-off function shuts down the machine when idling, further lowering energy costs.

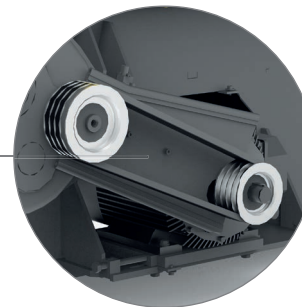

Options

Mechanical extras

- » Screw conveyor

Electrical extras

- » Control system upgrade (light barrier)
- » Integration of peripheral devices into the control system
- » Suction mechanism activation
- » Automatic start

Accessories

- » Customer-specific undercarriages
- » Range of discharge feed systems (conveyor belts, ...)
- » Range of metal separation units

Service

- » UNTHA Carefree Packages (Basic, Standard, Professional): Ensure that machines are technically sound and ready for use at all times

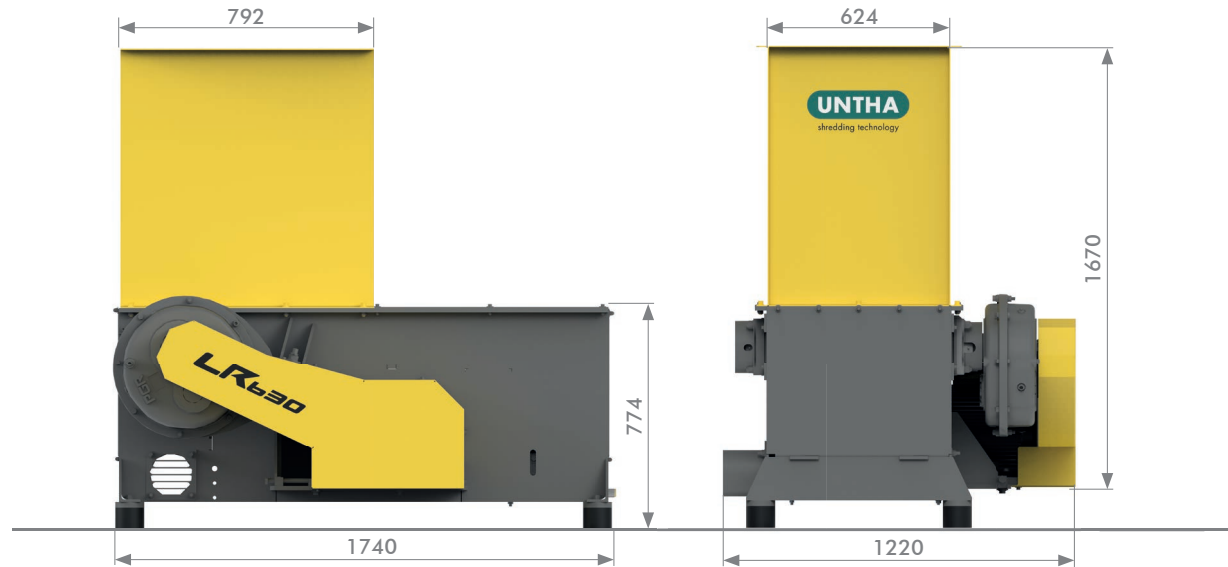

TECHNICAL DATA		LR630
Rated capacity of the rotor	kW	11/15/18.5
Rated capacity of the hydraulic system	kW	0.75
Ø Rotor	mm	248
Rotor speed	rpm	85 - 98
Number of indexable inserts	pcs.	17
Feed opening	mm	624 x 792
Ø Suction nozzles	mm	160
Required suction speed	m/s	28
Weight	kg	approx. 1,300
Workspace-specific sound pressure level LPA 1m	dB (A)	82
Ø perforated screen	mm	15 - 30
Throughput rates*	srm/h	Up to 2

*) Dependent on type of material and diameter of perforated screen
All dimensions in mm

