

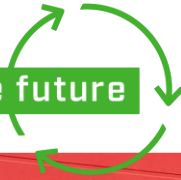

smicon

improve the process

improve the future



GRINDING



SMIM015

The rotor inside the SMIMO grinder pulverizes organic products into a homogeneous pulp which is suitable for pumping. A sieve inside the grinder ensures that the product is only discharged once the particles have the required size. The noise level can be reduced by an acoustic cover (if necessary). Parts can be easily exchanged, and the grinder is very resistant to aggressive products and substances.

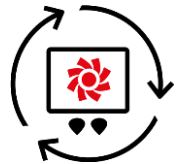

- ▶ Resistant to aggressive products and substances
- ▶ A sieve inside the grinder ensures that the product is discharged once the particles have the required size
- ▶ Made from stainless steel

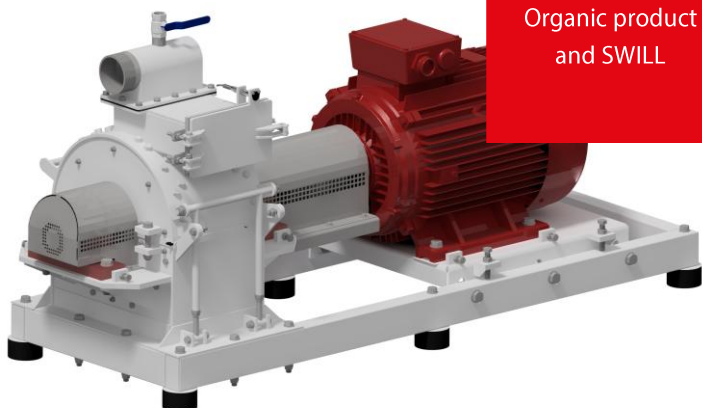

INPUT
Organic product
and SWILL



OUTPUT
Homogeneous
stream



SMIM015

TECHNICAL DATA

Dimensions	
Machine general	2130x765x970 mm (LxWxH)
Infeed	331x205 mm (LxW) (side infeed) 4" (top infeed)
Outfeed	600x350 mm (LxW)
Transport dimensions	2130x765x1120 mm (LxWxH)
Transport volume	1,58 m ³
Clear zone	3630x2365 mm (LxW)
Sieve mesh size	Ø3,Ø10,Ø15,Ø20, Ø25 or □5 mm
Weight	
Weight	850 kg
Floor load	3 kN (per bearing surface)
Transport weight	850 kg
Drive	
Power	18 up to 75 kW
RPM shaft	1500 to 3000 RPM
IP rating	IP56
Product information	
Capacity	15-25 ton / hour
Temperature product	1-70 °C
Other specifications	
A-weighted sound pressure level	88 dB
C-weighted instantaneous sound pressure	<130 dB
All data are without accessories and specifications depend on input product	
Illustrations (side infeed)	

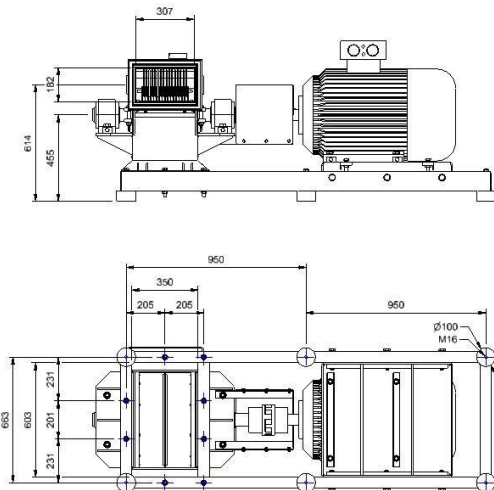

Accessories	
Frame with/without tank	Acoustic cover
Splash chute	Service box
Clearance area and illustrations (top infeed)	

