



GREMAC

Mobile Drum Screens





GREMAC

Mobile Drum Screens



GREMAC eZero

Whether excavated soil, stones, rubble or other screenable materials, the GREMAC eZero masters all tasks with ease.

Simple, robust, versatile - the GREMAC eZero

Up to 50 m³/h screening capacity

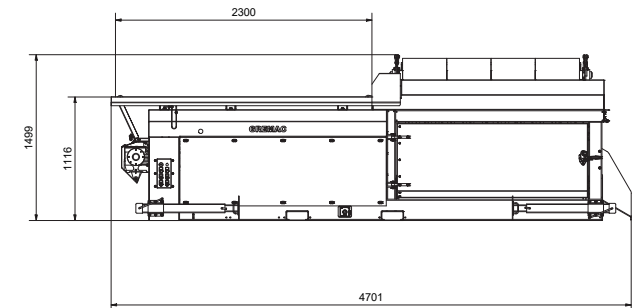
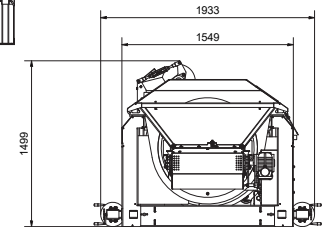
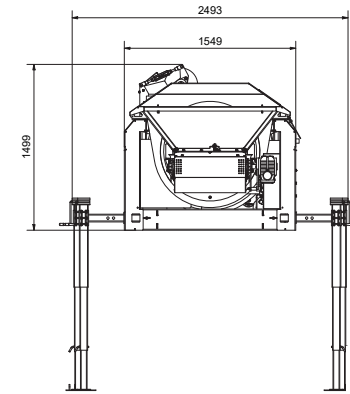
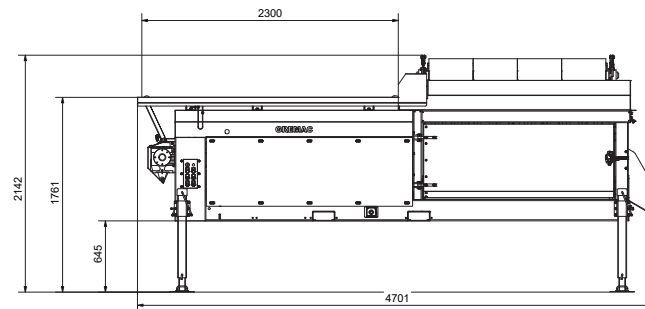
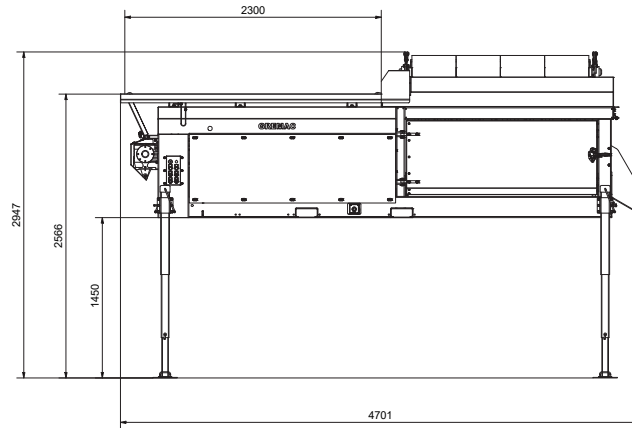

Contact



www.gremac.de

Technical Data

Drum length: 2,000 mm
Diameter: 1,000 mm
Screening surface: 6.2 m²
Mesh size: 2 - 80 mm

Drive: Electric (optionally available with petrol or diesel generator)

Hopper: 1.3 m³
Weight: 1,500 kg
Supply voltage: 380 - 420 V / CEE-16A

Robust, galvanised & Made in Germany

#screeningmadesimple